



Remote Control

SWING AUGER MOVER &

TRANSPORT WINCH Series II

INSTALLATION and OPERATING INSTRUCTIONS

The **G.Force** Remote Control is designed to provide the ultimate in convenience and safety to perform tasks remotely. It is a radio frequency (RF) controlled device that allows operation of a motor, gate, chute, etc. from a hand held transmitter operated remotely. The Transmitter, which operates at 418 MHz FM, transmits encoded information to the Receiver, which then decodes the information and performs the desired function. When coupled with the electromechanical driver, this system may be used to operate a motor, open a swinging gate, close a chute, turn a valve, etc. The Transmitter and Receiver are designed to operate within 300' but actual range is dependent on operating environment.

Features :

- Simplicity of design and quality of engineering.
- Power On/Off switch on Receiver Console
- Direction Control switch on Console
- User selectable security code
- LED Indicator lights.
- 9v Transmitter Battery
- Ease of installation/removal when not in use.
- All controls can be by either Manual Switch or Remote Control
- Multiple Transmitters can operate a single Receiver.
- Multiple Receivers can be operated by a single Transmitter.
- Receivers are "Channel selectable"
- Optional Auxiliary 12VDC output for remote controlled light or other device

Manufactured By: **Brehon Agrisystems Inc.**
 102 – 2750 Faithful Ave. Box 3
 Saskatoon, SK S7K 6M6 Maymont, SK S0M 1T0
 (306) 933 2655 phone/fax
 Web: www.brehonag.com Email: garth.brehon@sasktel.net

Brehon Agrisystems Inc. is not responsible or liable for indirect, special, or consequential damages arising out of or in connection with the use or performance of the product or other damage with respect to any economic loss, loss of property, loss of revenue or profit, or costs of removal, installation, or reinstallation.

Specifications:

Transmitter:

Power:	9 volt dc battery
Frequency:	418 MHz
Modulation:	FM
Indicators:	Power/Transmit Red LED
Case Size:	2.5" x 4.2" x .8"
Weight:	.25 lb.
Range:	300'+ (depending on environment)
Antenna:	1.3" Fixed Mini Tuned
Security Code:	3 ⁸ selections
Functions:	2 to 9 Button (depending on Model)

Receiver:

Power In:	12 vdc
Power Out:	12 vdc @ 100 amps max
Standby:	40mA
Security Code:	3 ⁸ selections
Power Input:	4ga. 2-conductor wire with "powerpole" connectors
Indicators:	Power On Red LED Receive RF Data Yellow LED Channel Active Green LED
Options:	Multi-Channel Operation (1-4) Main Power On/Off Switch Manual Switch Control
Antenna:	7" Flexible Tuned

<p>Brehon Agrisystems Inc. is not responsible or liable for indirect, special, or consequential damages arising out of or in connection with the use or performance of the product or other damage with respect to any economic loss, loss of property, loss of revenue or profit, or costs of removal, installation, or reinstallation.</p>

Electric Motor Drive

Electrical:	12vdc @ 100A Full Load
Torque:	1125 in-lb
Speed:	60 rpm no load
Output Shaft:	¾" keyed and drilled
Duty Cycle:	5%
Overall Size:	4" x 6" x 15"
Weight:	16 lb.

MECHANICAL ASSEMBLY DRAWING

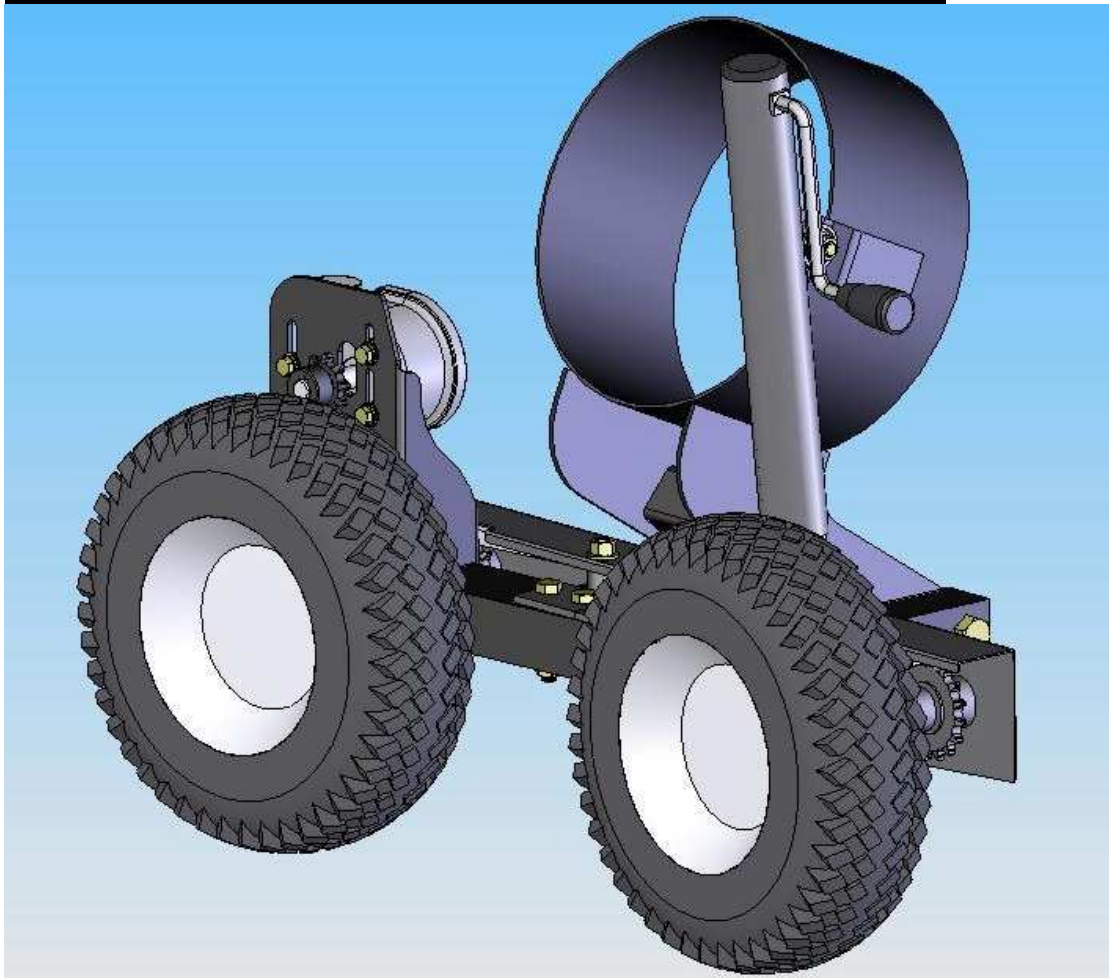

Brehon Agrisystems Inc. is not responsible or liable for indirect, special, or consequential damages arising out of or in connection with the use or performance of the product or other damage with respect to any economic loss, loss of property, loss of revenue or profit, or costs of removal, installation, or reinstallation.

INSTALLATION INSTRUCTIONS

Mechanical Installation:

The *G.Force* Swing Auger Mover is designed to clamp directly onto the swing auger tube at the lowest point. Using the six 7/16 x 2-1/2" bolts provided, tighten the clamp around the tube such that the main beam is horizontal when the hopper is on level ground and the auger is at its normal working height. Clamps are available for 10", 12", 13", 14" and 16" Augers.

MOUNTING POSITION

Clamp the Swing Auger Mover Drive at the lowest point possible on the swing auger tube so that, on level ground, the Main Beam is level without extending the jack, and all of the weight is off the inside wheels of hopper.

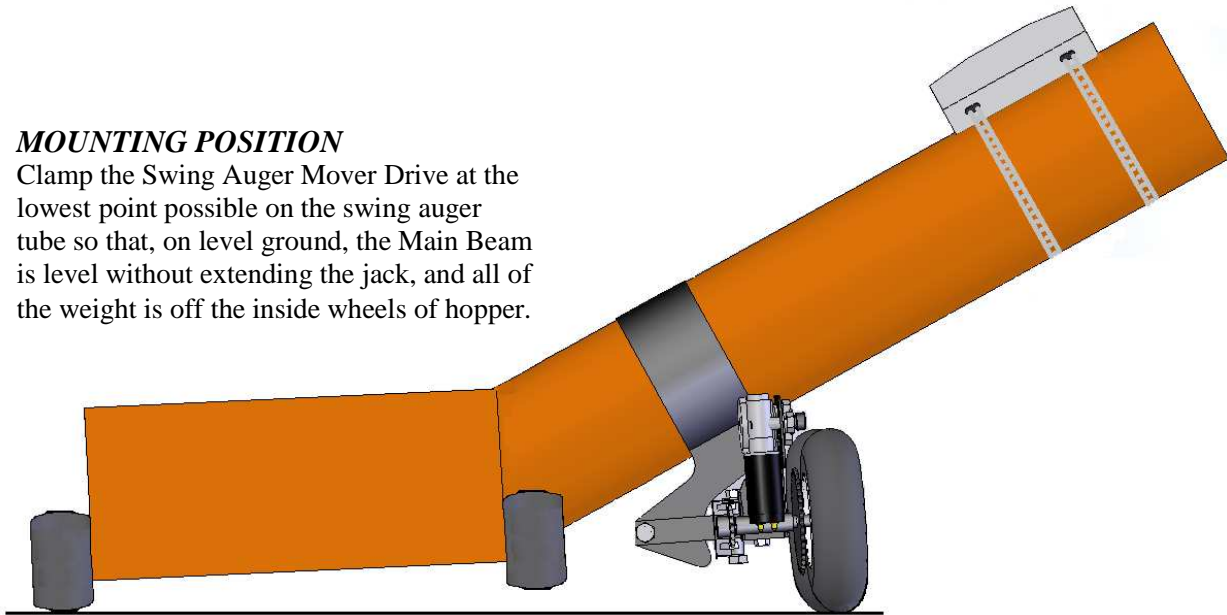

There is a grease nipple located on each axle sleeve. Grease before first operation and thereafter, as needed.

Think Safety:

**Do Not install or operate where
damage to property or persons may occur.**

Brehon Agrisystems Inc. is not responsible or liable for indirect, special, or consequential damages arising out of or in connection with the use or performance of the product or other damage with respect to any economic loss, loss of property, loss of revenue or profit, or costs of removal, installation, or reinstallation.

Electrical Installation:

The **G.Force** Swing Auger Mover is provided with pre-cut wire lengths with color-coded connectors attached.

Cable Schedule:

Tractor Power Cable - 12' c/w Red/Black PowerPole Connector.
 Console Power Cable - 9' c/w Red/Black PowerPole Connector
 Console/Swing Cable - 6' c/w Black/Black PowerPole Connector
 Console/Winch Cable - 14' c/w ¼" Ring Terminals

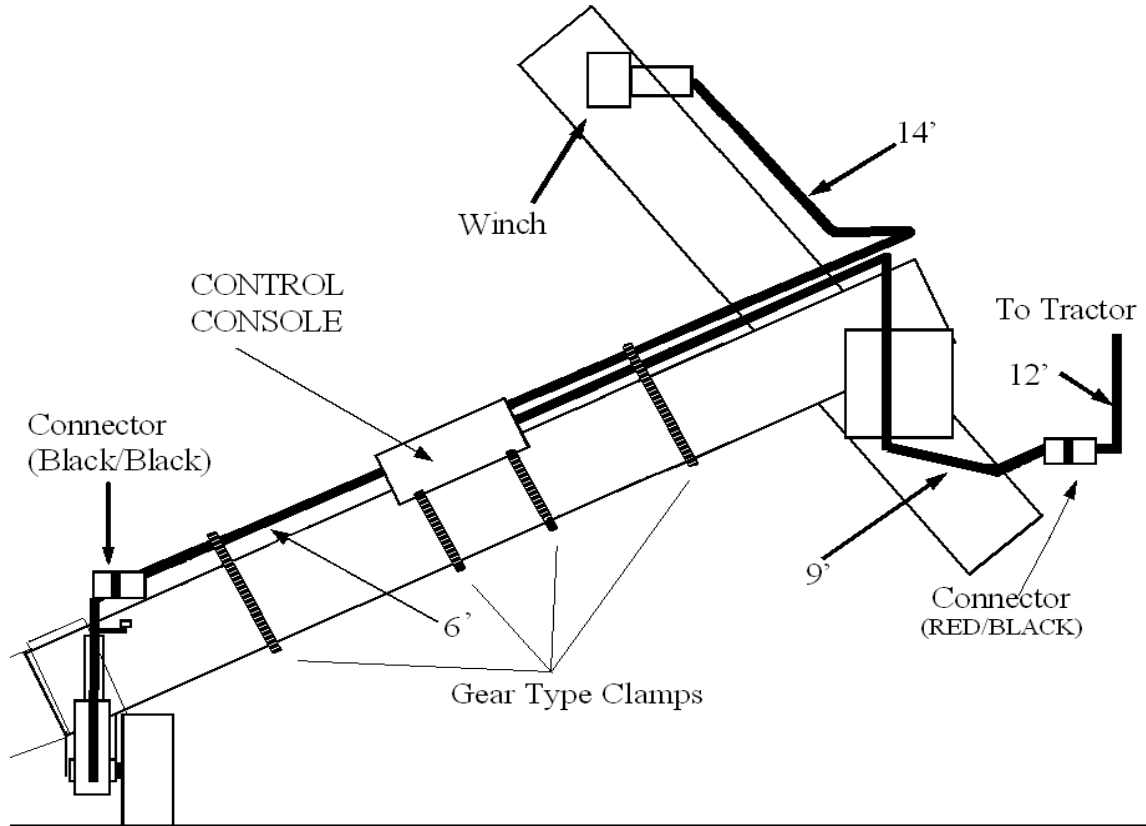

The polarity **must** be correct as follows: +12v on the RED STRIPE wire on the POWER CABLES FROM THE TRACTOR TO THE CONTROL CONSOLE. The RED /BLACK connector shells **MUST MATCH**.

WARNING: DO NOT ATTEMPT TO POWER THE CONSOLE OR DRIVE FROM A BATTERY CHARGER ALONE AS DAMAGE MAY OCCUR. CONNECT TO A PROPERLY MAINTAINED BATTERY SYSTEM ONLY.

Brehon Agrisystems Inc. is not responsible or liable for indirect, special, or consequential damages arising out of or in connection with the use or performance of the product or other damage with respect to any economic loss, loss of property, loss of revenue or profit, or costs of removal, installation, or reinstallation.

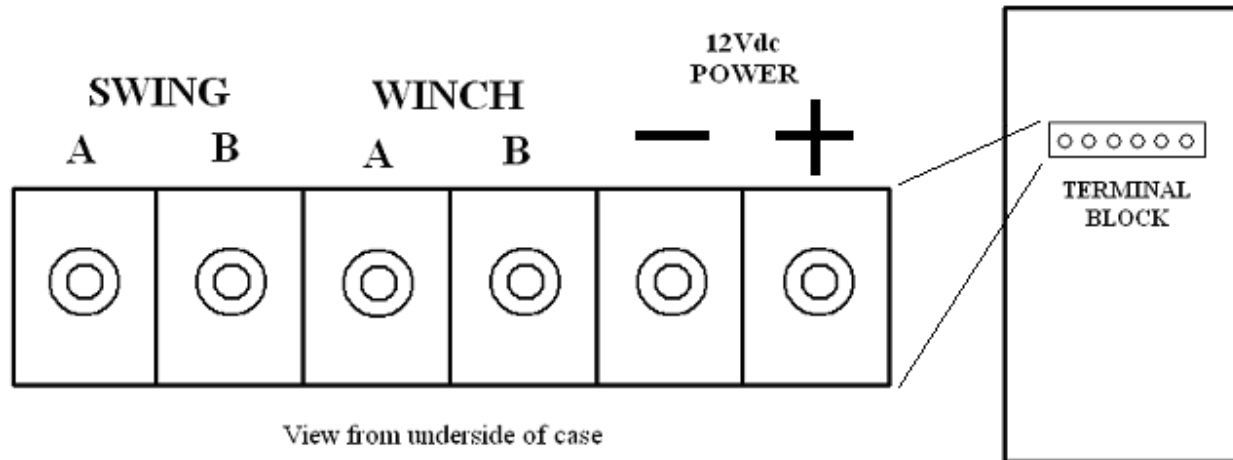

Connect the 6' Console/Swing cable, 14' Console/Winch cable and the 9' Console/Power cable to the terminal block on the underside of the Swing Auger Mover Console using the lock washers and 1/4"-20 aluminum nuts supplied. Attach the Swing Auger Mover Console at a convenient height on the swing auger tube using the gear type clamps provided through the console holes.

Install the 12' Tractor Power cable onto the 12V tractor battery terminals, using the pre-crimped 3/8" ring terminals and the 80A self resetting fuse assembly included. The fuse assembly must be installed between the positive battery terminal and the Red conductor of the 12' Tractor Power cable to protect against the possibility of a short circuit. Be sure to install the fuse assembly observing the correct polarity as indicated by the engraved "BATT" label on the aluminum fuse bar.

Install the Transport Winch and connect the 14' Console/Winch cable onto to the winch motor terminals, using the pre-crimped 1/4" ring terminals.

Connect the 6' Console/Swing cable to the Swing Auger Mover wheel assembly motor cable.

The polarity for the Swing A/B and the Winch A/B terminals will reverse during normal operation. If the Wheel Drive is running in the wrong direction when operated, exchange the Swing A and B wires. Similarly, if the Winch is running in the wrong direction when operated, exchange the Winch A and B wires.

Connect the 9' Console/Power cable to the 12' Tractor Power cable.

Secure cables to the swing auger tube using the supplied gear type clamps as shown.

WARNING: DO NOT CONNECT THE TRACTOR POWER CABLES TO THE CONTROL CONSOLE OUTPUT TERMINALS AS AN ELECTRICAL SHORT AND SERIOUS DAMAGE OR INJURY COULD RESULT!!!

Brehon Agrisystems Inc. is not responsible or liable for indirect, special, or consequential damages arising out of or in connection with the use or performance of the product or other damage with respect to any economic loss, loss of property, loss of revenue or profit, or costs of removal, installation, or reinstallation.

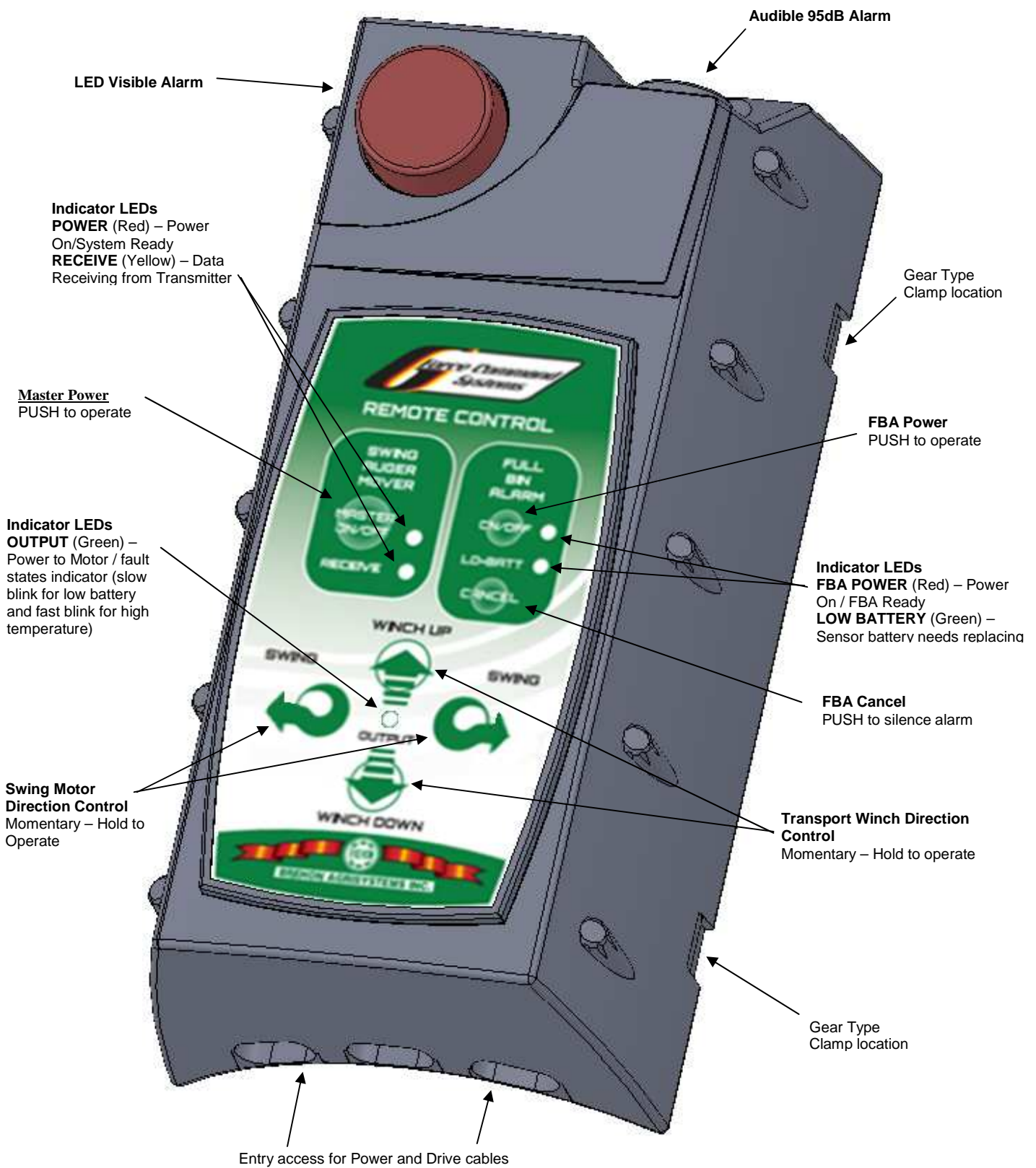

Brehon Agrisystems Inc. is not responsible or liable for indirect, special, or consequential damages arising out of or in connection with the use or performance of the product or other damage with respect to any economic loss, loss of property, loss of revenue or profit, or costs of removal, installation, or reinstallation.

General Operation:

Control Console:

The Control Console contains the Receiver and power control circuits. The Control Console is equipped with a Master Power On/Off switch on the outside of the case. When the switch is ON, the Red LED should be lit indicating normal operation. Press and release to turn On and Off.

Each of the Swing Auger Drive and Winch may be operated independently from the Control Console by pressing the desired momentary switch. The Green “Output” LED will come on and the selected device will operate.

The Control Console also has built-in fault status indicators. For ease of troubleshooting, if a “low voltage” status occurs to the Control Console, the green LED will blink approximately twice per second. Check all connections to ensure they are clean and tight. Make sure that the tractor battery is fully charged, and the engine is running. If a “control circuit high temperature” status occurs the Green LED will flash rapidly, blinking approximately four times per second. Allow the unit to cool before resuming operation.

Each **G.Force** Swing Auger Mover has its own RF receiver located in the control console, which is channel selectable to operate in multi-component environments e.g. remote control trailer chutes on Channels 1 & 2, and the **G.Force** Swing Auger Mover on Channel 3. The user can select the desired channel using the 2-position dip-switch. All **G.Force** Swing Auger Movers are set to Channel 1 at the factory.

AUXILIARY OUTPUT (OPTION):

The Control Console Auxiliary Output provides a remote control power output capable of delivering 10A (120 watts). This feature is intended for the operation of a remote control light for illuminating the work area when approaching at night, or for operation of a camera or other device. The output can be activated and deactivated from the transmitter by pressing the centre button on the RF transmitter (marked STOP), or from the Control Console by pressing the two Swing control buttons on the face of the Control Console simultaneously. The auxiliary output is protected by a thermal fuse that automatically resets when cooled. The auxiliary output is automatically shut off when the fuse trips to prevent a repeating cycle of the fuse tripping and resetting and must be reactivated using the transmitter or Console controls.

The Auxiliary output option includes a 5-foot length of cable to connect the Control Console to the 12V device. The polarity is as follows: **+12V on the WHITE wire**, and **GROUND on the BLACK wire**.

The auxiliary output connector is factory installed at the top left access hole near the swing output, but it can be installed at any of the Control Console case's six entry access holes. To move the

Brehon Agrisystems Inc. is not responsible or liable for indirect, special, or consequential damages arising out of or in connection with the use or performance of the product or other damage with respect to any economic loss, loss of property, loss of revenue or profit, or costs of removal, installation, or reinstallation.

connector, open the Control Console case by removing the fourteen #10 x 1” screws and separating the top and bottom halves of the case. Remove the jam nut holding the auxiliary output connector in place and slide the connector out of its plastic case insert. Insert the output cable through the desired access hole and slide the case insert back onto the cable with the round side toward the front of the receiver case. Fasten the jam nut onto the connector by hand to hold the connector in place, lining up a flat edge of the jam nut with the flat edge of the case insert. Slide the insert into the access hole and reattach the top and bottom of the receiver case together.

SECURITY CODE:

The Receiver is equipped with an 8-position tri-state switch to set the user security code. The security code is provided to prevent unwanted operation of the Receiver by other devices. Only a Transmitter with identical switch settings will be able to "talk" to this Receiver. When the switches are set identically and the transmitter "talks" to the Receiver, the yellow "RECEIVE" LED will light. This indicates that valid data with a matching security code has been received. Position these switches to any desired On/Off pattern for your own security code. **REMEMBER:** The 8-position switch on the Transmitter must be set **IDENTICALLY**. To access the security code switch, remove the screws on the underside of the Control Console to access the Receiver. The security code switch is mounted on the Receiver circuit board.

Brehon Agrisystems Inc. is not responsible or liable for indirect, special, or consequential damages arising out of or in connection with the use or performance of the product or other damage with respect to any economic loss, loss of property, loss of revenue or profit, or costs of removal, installation, or reinstallation.

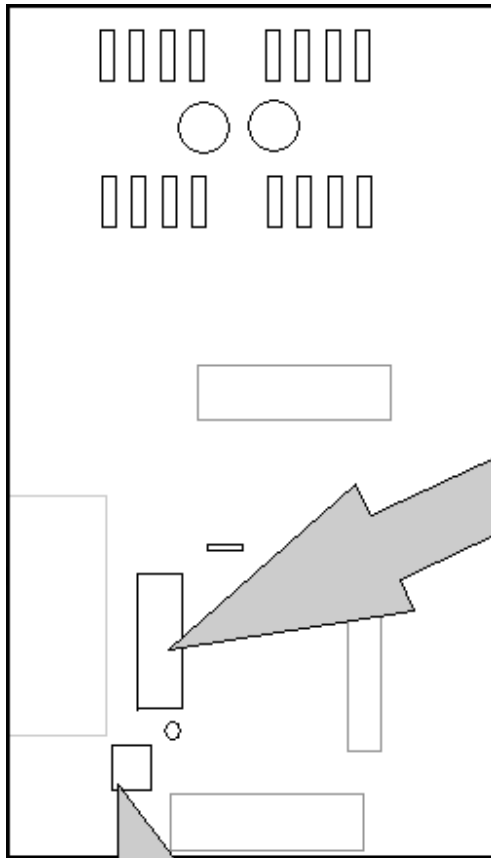

SECURITY CODE SWITCH

USER SELECTABLE 8 - Switch SWITCH MUST BE SET IDENTICALLY TO THE TRANSMITTER

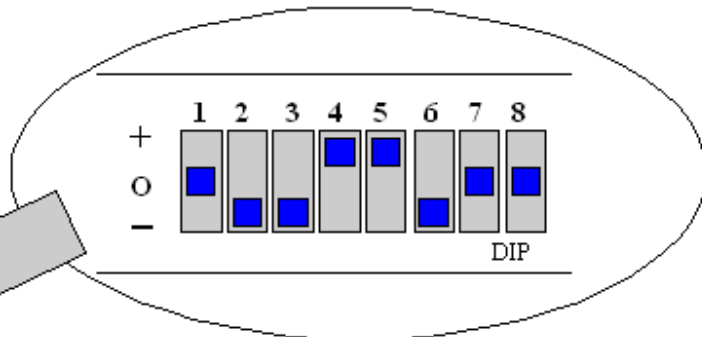

NOTE: This is a TRI-STATE switch.
 Each of the 8 switches has **3 positions** which must be identically matched to the corresponding Transmitter. These code switches are fully compatible with 8-position Two- State On/Off switches by using the “+” setting as ON and the “O” setting as OFF.

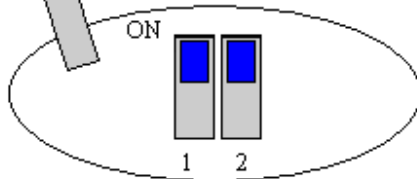

CHANNEL SELECT SWITCH

Two Switch 2-Position Selector to match Receiver with Transmitter channel output

Brehon Agrisystems Inc. is not responsible or liable for indirect, special, or consequential damages arising out of or in connection with the use or performance of the product or other damage with respect to any economic loss, loss of property, loss of revenue or profit, or costs of removal, installation, or reinstallation.

CHANNEL SELECT **SETTINGS:**

The **G.Force** Swing Auger Mover comes with a 2-position DIP Switch to match the Drive to the desired transmitter channel. In multi-component environments, be sure that each drive is set to a different channel so that devices do not operate simultaneously. Select the switch settings as follows:

	Switch 1	Switch 2
Channel 1	OFF	OFF
Channel 2	ON	OFF
Channel 3	OFF	ON
Channel 4	ON	ON

The **G.Force** Swing Auger Mover and Winch can be operated using the Transmitter, or alternatively, by operating the UP/DOWN momentary switches on the Control Console. Whenever the **G.Force** Swing Auger Mover drive or Winch is operated by remote control the Yellow “Receive Data” LED will be lit along with the Green LED indicating power output to the drive.

The **G.Force** Swing Auger Mover has two automatically resetting fuses. Fuse F1 (1 Amp) inside the control console is intended to protect the RF receiver and data circuitry, and Fuse F2 (80 Amp) at the battery is intended to protect against a short circuit in the cables. These fuses will automatically reset when cooled.

The Control Console power switch should be turned Off when not in use to prevent undesired operation.

TRANSMITTER:

The Transmitter is powered by a 9v battery which, when installed, should light the red "power" light when a switch is pressed. If the battery does not exceed 7 volts the Power light will not come On, indicating battery replacement is required.

The Transmitter is also equipped with an OFF/Standby switch to prevent accidental operation. In the OFF position the transmitter Red LED will not light and the transmitter will not activate even when a function button is pressed. To operate, slide the switch to STANDBY. The transmitter remains off until a function button is pressed, at which time the Red LED will light and the transmitter will emit signal. No battery power is used when simply in Standby mode with no function buttons pressed.

Brehon Agrisystems Inc. is not responsible or liable for indirect, special, or consequential damages arising out of or in connection with the use or performance of the product or other damage with respect to any economic loss, loss of property, loss of revenue or profit, or costs of removal, installation, or reinstallation.

Set the 8-position switch to your own security code which matches the code on the Receiver to which it is to "talk". Note that any number of Transmitters can "talk" to the same Receiver as long as they have the security code that matches the receiver.

To access the Transmitter security code switch or battery, remove the 4 screws in the back of the Transmitter case and open the case.

Brehon Agrisystems Inc. is not responsible or liable for indirect, special, or consequential damages arising out of or in connection with the use or performance of the product or other damage with respect to any economic loss, loss of property, loss of revenue or profit, or costs of removal, installation, or reinstallation.

TRANSPORT WINCH

The Transport Winch is provided for ease of lifting of the swing auger and hopper to and from the transport position. This electric winch operates on 12Vdc power provided through the Control Console and can be operated by manual switch on the Console, or by remote control.

The customer can decide the optimum mounting location and utilization for each application. The electric winch may be employed to replace the existing hand-crank winch or alternatively, to operate in addition to the hand-crank winch.

It is recommended to utilize the auger manufacturer's pulleys and guides provided for the hand-crank winch to ensure the swing auger and hopper lifts as designed. In addition, remove any excess cable so as to reduce the number of cable layers on the winch drum and thus maximize capacity. To further increase winch capacity, a pulley block and hook can be utilized to effectively double the load capacity.

To install the winch on the mounting plate provided, the customer should unwind the cable to get access to the two mounting holes, which are located underneath the drum. Unwind the cable until you have enough space to drop a bolt through each hole then screw the nuts on from the bottom.



The Transport Winch option uses a Superwinch C1000 12vdc electric winch, which provides 5000lb. line pull (bottom layer) manufactured by Superwinch Inc.

It is imperative for the user to follow all winching instructions as contained in the Superwinch Owner's Manual.

OWNER'S MANUAL

INSTALLATION • OPERATION • MAINTENANCE
SAFETY PRECAUTIONS • REPAIR PARTS

C-SERIES

12 Volt DC Electric Winch
Models 03001

Think Safety:

**Do Not install or operate where
damage to property or persons may occur.**

Think Safety:

**STAND CLEAR WHILE OPERATING and ALWAYS USE
SAFETY CHAIN WHEN RAISED**

Brehon Agrisystems Inc. is not responsible or liable for indirect, special, or consequential damages arising out of or in connection with the use or performance of the product or other damage with respect to any economic loss, loss of property, loss of revenue or profit, or costs of removal, installation, or reinstallation.